

# Appendix 11

[RETURN TO APPENDICES LIST](#)

## High Voltage Power Supply Upgrade (Welcon Technologies Pty Ltd)

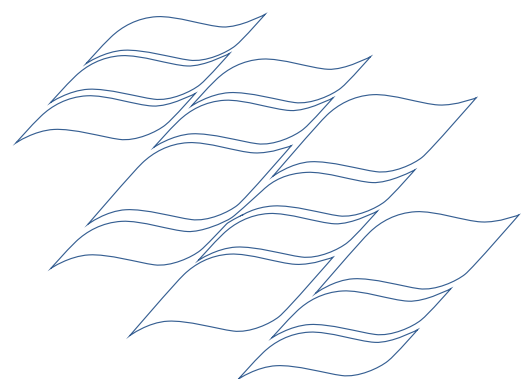

# GLADSTONE AREA WATERBOARD

## AWOONGA DAM



## HIGH VOLTAGE POWER SUPPLY UPGRADE





**Welcon Technologies Pty Ltd**  
As Trustee for Welcon Unit Trust  
ABN 66 306 990 591

<http://www.welcon.com.au>  
[welcon.gladstone@welcon.com.au](mailto:welcon.gladstone@welcon.com.au)

**Gladstone Office**  
Phone: (07) 4976 0600  
Fax: (07) 4972 4820  
PO Box 307 GLADSTONE 4680

Level 3  
100 Goondoon Street  
GLADSTONE 4680

**Townsville Office**  
Phone: (07) 4721 1448  
Fax: (07) 4721 1148

Unit 1  
33 Plume Street  
SOUTH TOWNSVILLE, QLD 4810

**Welcon Technologies Pty Ltd**

This document is and shall remain the property of Welcon Technologies Pty Ltd. The document may only be used for the purpose for which it was commissioned and in accordance with the Conditions of Appointment – Engineering Services. Unauthorised use of this document in any form whatsoever is prohibited.

Document Status					
Date	Rev	Description	Author	Checked	Approved
18/02/2008	A	Preliminary Issue for Information	<i>A. Davis</i>	<i>S. Williams</i>	
11/03/2008	B	Issued for Use	<i>A. Davis</i>	<i>R. Kane</i>	<i>S. Williams</i>



# TABLE OF CONTENTS

<b>1</b>	<b>INTRODUCTION</b>	<b>5</b>
1.1	General	5
1.2	Background	5
<b>2</b>	<b>SITE INSPECTIONS</b>	<b>6</b>
2.1	Data Gathering	6
2.2	Pump No. 3	6
2.3	Switchroom Audit	6
<b>3</b>	<b>EXISTING EQUIPMENT</b>	<b>7</b>
3.1	11kV Switchgear	7
3.2	3.3kV Switchgear	10
3.3	Intake Tower Power Supply	13
3.4	415V Distribution Load Centre LC01	16
3.5	River Outlet Discharge Power Supply	17
3.6	11 kV Supply Poles	18
<b>4</b>	<b>OPTIONS FOR HV SWITCHGEAR UPGRADE</b>	<b>19</b>
4.1	Option 1 Replacement of Existing Switchgear	19
4.2	Option 2 Installation of a Ring Main Unit	19
4.3	Option 3 Installation of a Third 3MVA Transformer	20
<b>5</b>	<b>SWITCHGEAR REPLACEMENT METHODOLOGY</b>	<b>21</b>
5.1	Install Air Break Switches	21
5.1.1	Overhead 11kV Supply 1	21
5.1.2	Overhead 11kV Supply 2	21
5.2	Install Third 3MVA Transformer	22
5.3	Removal and Installation of 3.3kV Switchgear	22
5.4	Removal and Installation of 11kV Switchgear	22
5.4.1	Partial Removal of Switchgear	22
5.4.2	Bustie Removal	22
5.4.3	Switchgear Installation	23
5.4.4	Remove Remaining Old Switchgear	23
5.4.5	Second Half Switchgear Installation	23



<b>6</b>	<b>PROTECTION RELAYS</b>	<b>24</b>
<b>7</b>	<b>INTAKE TOWER POWER SUPPLY</b>	<b>25</b>
<b>8</b>	<b>LOAD CENTRE LC01</b>	<b>26</b>
<b>9</b>	<b>RIVER DISCHARGE POWER SUPPLY</b>	<b>26</b>
<b>10</b>	<b>11KV SUPPLY ISOLATION</b>	<b>26</b>
<b>11</b>	<b>COSTING</b>	<b>27</b>
11.1	Cost Estimate Summary of Options	27
11.2	Cost Estimate Summary of Common Project Components	28
<b>12</b>	<b>RECOMMENDATION</b>	<b>29</b>

## **APPENDICIES**

<b>APPENDIX A</b>	Option 2 Drawings	<b>28</b>
<b>APPENDIX B</b>	Option 3 Drawings	<b>32</b>



# 1 INTRODUCTION

## 1.1 General

The Gladstone Area Water Board intends to replace the ageing High Voltage Switchgear at Awoonga Dam, as well as make some other minor changes to the electrical distribution system at the dam to improve reliability and safety.

This report provides the results of investigations by Welcon Technologies, and presents the recommended methodology for replacing the switchgear, without compromising the essential water supply delivery system to Gladstone and its associated industries. To assist in these investigations site layout drawings, equipment drawings and schematics were supplied by GAWB.

## 1.2 Background

The 11kV and 3.3kV switchgear at the Awoonga Dam pumping station were installed circa 1978 and have reached the end of their design life. The switchboards have not been refurbished and parts are becoming difficult or impossible to procure.

The original intake tower is supplied with high voltage to a transformer that in turn supplies 415V to a switchboard of similar vintage to the HV switchboards. Replacement parts are also becoming increasingly difficult to source. The high voltage transformer and isolator for the switchboard are located in an area of the intake tower that may be subject to flooding in the future.

There is no power supply available at the river discharge outlet area requiring the use of a diesel generator to power a hydraulic power pack to operate the discharge valves.



## 2 SITE INSPECTIONS

### 2.1 Data Gathering

Site inspections were carried out on 14<sup>th</sup> and 20<sup>th</sup> of January 2008.

Information was gathered in the form of photos, switchboard dimensions, termination heights, protection settings and switchroom dimensions.

The cable route and length was determined for the river discharge power supply.

Inspection included:

- 11kV switchroom and HV switchgear
- 3.3kV switchroom and switchgear
- Substation basement and cable entry
- Pad mount transformer and distribution board at auxiliary intake tower
- 3.3kV/415V transformer, switchgear and distribution board at old intake tower.
- Pump station distribution board.
- Office distribution board
- Load centre LC01

### 2.2 Pump No. 3

To start the Standby Pump No.3, the normal condition is to have two 3MVA transformers operational and connected in parallel.

During the visit on the 14<sup>th</sup> of January, a test was carried out to ascertain if the standby pump No.3 could be started and run with only one 3MVA transformer in circuit. For this test 11kV Incomer 1 was opened and the 11kV bus tie left open. This test had not been carried out since a soft starter was installed in early 2002.

During this test, the pump tripped as a result of an over current trip on Transformer No3 after approximately four seconds.

This test confirmed that it is essential to have two 3MVA transformers in parallel to start the Standby Pump.

### 2.3 Switchroom Audit

To ensure that the switchrooms themselves complied with the latest requirements of the Qld Electricity Act, a separate inspection was carried out.

The results of this audit are in Report GJ543-RP-01B.



## 3 EXISTING EQUIPMENT

### 3.1 11kV Switchgear



11kV switchgear manufactured by Ramsay Engineering P/L and installed in the early 80s will be replaced with modern equipment.



Three single core 630sqmm cables supplying 11kV directly from the service pole



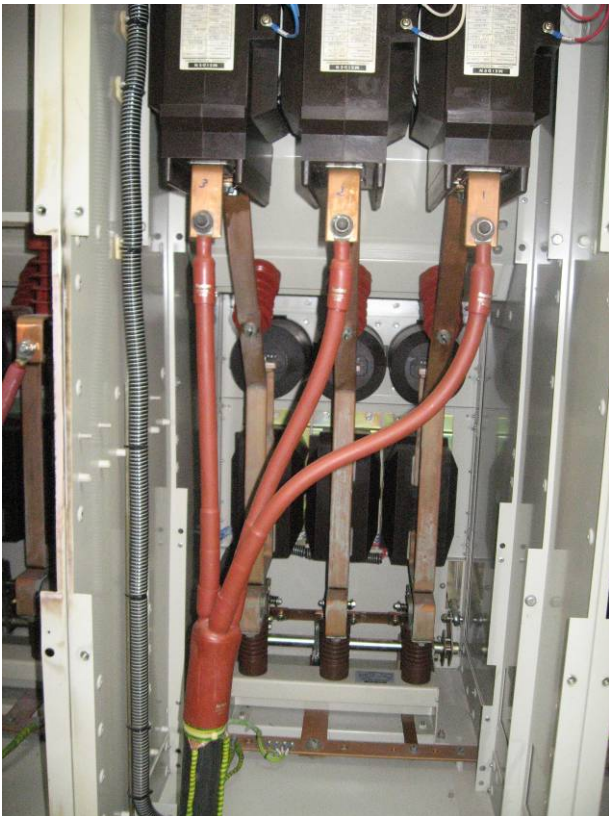

3 core 70sqmm XLPE cable  
supplying 11kV to the primary  
of Transformer No.1



3 core 70sqmm XLPE  
cable supplying 11kV to  
the VSD No.3



Rear view of 11kV switchgear showing fire suppression fitted to the integral house transformer enclosure. The house transformers supply 415V power to the office distribution board. The house transformers will be removed in the HV upgrade and power for the office DB will be supplied from load centre LC01.



VSD feed

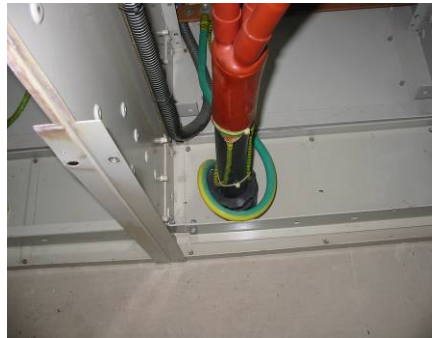

Transformer feed  
Cable entries



11kV incomer



## 3.2 3.3kV Switchgear



3.3kV switchgear manufactured by Ramsay Engineering P/L and installed early 80s will be replaced with modern equipment.



Two 3 core 185sqmm cables from the secondary side of Transformer No.3 supplying 3.3kV.



Two 3 core 185sqmm cables  
from the secondary side of  
Transformer No.1 supplying  
3.3kV.

Incoming 3.3kV supply from transformer No.1



Two 3 core 185sqm cables  
supplying 3.3kV to Pump  
No.3

Outgoing 3.3kV supply to Pump No.3



3 core 35sqmm XLPE cable  
supplying 3.3kV to the  
services transformer

Outgoing 3.3kV supply to services transformer



3 core 16sqmm XLPE cable  
supplying 3.3kV to the  
Chlorinator House and Intake  
Tower transformers

3.3kV to chlorinator house

3.3kV to intake tower



Rear view of 3.3kV switchgear

### 3.3 Intake Tower Power Supply



Original Intake Tower will be flooded if the dam reaches 100% capacity



Pad mounted 3.3kV/415V transformer located at the Auxiliary Intake Tower. 415V supplies the Distribution Board to the left of the transformer. This DB supplies gantry hoists spillway & area lighting and GPO's.



Pad mounted transformer showing 3.3kV supply from sub station entering the bottom of the isolating link arrangement. The cable leaving the centre section of the isolation links supplies 3.3kV to the Old Intake Tower. Cables leaving the right hand side links supplies 3.3kV to the primary side of the pad mount transformer.



Old Intake Tower  
3.3kV/415V transformer  
that may be subject to  
flooding in the future. The  
concern is that 3.3kV will  
be present at the  
transformer when the tower  
floods.



Intake tower distribution  
board is a similar vintage to  
the HV switchgear and will  
be replaced during the  
upgrade. It is reported that  
the busbars are starting to  
crack and parts are difficult  
to source.







### 3.4 415V Distribution Load Centre LC01



LC01 Load Centre showing interlocked Main/Emergency Generator changeover switch arrangement.

LC01 in-come/ generator change over switch



The spare 160A cell in Load Centre LC01 will be utilized to supply 415V to the office distribution board once the 11kV house transformers are removed.



Spare cell 160A circuit breaker in LC01



### 3.5 River Outlet Discharge Power Supply



The river discharge can be seen in the distance with the pump house in the foreground.



The river discharge has no power supply available. The upgrade will include the installation of a three phase supply to a local distribution board. Provision for lighting, 240 GPO and 20A three phase outlet will be established.



The purpose of establishing a 240V outlet in the river discharge area is to provide power for the hydraulic power pack that is used to operate the outlet valve. In the past, a portable generator was required to supply power.



### 3.6 11 kV Supply Poles



Three single 630 sqmm cables are shown dropping from one of two overheads supplying 11kV to the high voltage switchboard installed in the substation. Part of the upgrade is to install air break switches at the overhead droppers on both service poles.



## **4 OPTIONS FOR HV SWITCHGEAR UPGRADE**

### **4.1 Option 1 Replacement of Existing Switchgear**

The existing HV switchgear can be replaced in the same configuration as the existing equipment. This option would offer new reliable switchgear that would be supported by the manufacturer for some years to come.

However this option does not supply full redundancy should a failure occur on one of the 11kV bus sections. (Two halves of the 11kV bus sections are separated by a bus tie). If such a fault occurred only one 3MVA transformer can be energized. The standby pump No.3 requires both 3MVA transformers to be in circuit whilst starting. GAWB would be left with one main pump only during times that a fault was present on the 11kV bus.

The Cost Estimate for Option 1 is illustrated in Table 1.

### **4.2 Option 2 Installation of a Ring Main Unit**

This option includes the replacement of the existing switchgear and the addition of a ring main unit (RMU). The RMU would be installed so that two 11kV inputs to the RMU would be taken from either side of the 11kV bus tie. Two feeders from the RMU would supply the two 3MVA transformers. A Fortress key system would be implemented to prevent both supplies to the RMU being closed at the same time.

This installation would offer security for pumping capacity should a fault occur on either side of the 11kV bus. GAWB would have one VSD available, plus pump No.3 which would be supplied from both 3MVA transformers, but from only one side of the 11kV bus.

Due to both transformers being supplied from one 11kV feeder, the size of the feeder cables from the 11kV switchboard to the RMU would have to be increased.

Drawings illustrating the Option 2 power system configuration are given in Appendix A.

Cost Estimate for Option 2 is illustrated in Table 1.



### **4.3 Option 3 Installation of a Third 3MVA Transformer**

This option includes the replacement of the existing switchgear and the addition of a ring main unit as well as the addition of a third 3MVA transformer. The RMU would be installed so that two 11kV supplies to the RMU would be taken from each of the two incomer poles via link fuses. The output from the RMU would supply the third 3MVA transformer. A Fortress key system would be implemented to prevent both inputs to the RMU being closed at the same time.

This option would offer security for maintaining pumping capacity should a fault occur on either side of the 11kV bus. GAWB would have one VSD available, plus pump No.3 which would be supplied by one of the 3MVA transformers plus the third 3MVA transformer that is supplied directly from each incomer pole via the RMU.

Drawings illustrating the Option 3 power system configuration are given in Appendix B.

Cost Estimate for Option 3 is illustrated in Table 1.



## 5 SWITCHGEAR REPLACEMENT METHODOLOGY

The major consideration when planning this installation is to maintain a degree of redundancy in pumping capability. At least two pumps should be available for pumping at all times. (i.e. both VSD pumps, or one VSD pump and the Standby Pump)

Option 1 does not allow this level of redundancy during the installation phase or in the final upgraded system.

Option 2 would require the hiring of a temporary portable sub station to provide the required level of redundancy during installation. Aside from the cost, the implementation steps would be more involved.

Option 3 provides this level of security during installation without the necessity of a temporary portable sub station.

The following replacement methodology describes the implementation of Option 3.

### 5.1 Install Air Break Switches

By completing the installation of ABS equipment on one pole before commencing on the other, 11kV supply can be maintained to the sub station. Once the ABS's are installed, the task of performing isolation for HV access will become much easier and not reliant on input from Ergon.

#### 5.1.1 Overhead 11kV Supply 1

- Replace the ageing links on the first aerial pole on the Ergon side of the spillway, to ensure reliable isolation during the upgrade.
- Install an air break switch (ABS) complete with earthing facility on the first aerial termination pole on the GAWB side of the spillway to provide local HV isolation.
- Install 200A fuse links on the same aerial termination pole, ready to accept the RMU supply cable.

#### 5.1.2 Overhead 11kV Supply 2

- Replace the ageing links on the second aerial pole on the Ergon side of the spillway, to ensure reliable isolation during the upgrade.
- Install an air break switch (ABS) complete with earthing facility on the second aerial termination pole on the GAWB side of the spillway to provide local HV isolation.
- Install 200A fuse links on the second aerial termination pole, ready to accept the RMU supply cable.



## **5.2 Install Third 3MVA Transformer**

Install the spare 3MVA transformer (ex-Toolooa Pump Station) and the new ring main unit in Transformer Bay No4. Install cables from the RMU to the isolating fuses installed on the aerial termination poles. Install the cable from the RMU to the primary of the new transformer. Install the cables from the secondary of the new transformer to the 3.3kV switchroom basement.

## **5.3 Removal and Installation of 3.3kV Switchgear**

The 3.3kV switchgear will be removed as one unit as there is no need to split the operation. A temporary diesel generator will be required to supply 415V power to load centre LC01 for the time that the 3.3kV board is de-energized.

200mm holes will have to be drilled in the concrete floor of the 3.3kV switchroom to accommodate cables as the new switchgear cable entry points will not match the old equipment.

During the 3.3kV switchgear change out both VSD supplied pumps will still be available. Diesel generators will be utilized to supply the distribution boards at the intake tower and auxiliary intake tower if required.

It is anticipated that the 3.3kV switchgear change out will take approximately two weeks. If necessary, remote monitoring of the generator can be arranged through the existing radio telemetry system.

## **5.4 Removal and Installation of 11kV Switchgear**

Due to the earlier installation of the ABS, isolation of the 11kV for access will not be an onerous task. The 11kV switchboard will be replaced in two separate operations.

### **5.4.1 Partial Removal of Switchgear**

After isolation of the 11kV supply, the house transformers will be removed together with the left hand side of the switchboard. This will remove the circuit breaker panels for Incomer No.1, VSD No.1 and Transformer No.1 feeder.

### **5.4.2 Bustie Removal**

Remove the bustie and transition busbars. After preparation of the bus section at incomer No2 circuit breaker place an end cover on the switchboard to make safe the exposed bus section. This will permit the right hand side of the switchboard to be re energized which in turn allows VSD No.2 or pump No.3 to be run. The apparatus removed will leave a space of approximately 2.5 metres between the substation wall and the No.2 incomer circuit breaker. This is ample room to fit the first half of the new switchgear which will be three modules each approximately 600mm wide.



### **5.4.3 Switchgear Installation**

The first half of the new switchgear will incorporate No.1 feeder, No.1 VSD and Transformer No.1 feeder. Enough room will exist between the old switchgear and the substation wall to manoeuvre the new switchgear into position. After preparation of cable entries, the new switchgear will be moved into place and fixed. Terminations will be carried out. Testing and commissioning will then be completed allowing the new switchgear to be energized.

### **5.4.4 Remove Remaining Old Switchgear**

After correct isolation the remaining half of the old switchgear may now be removed as the new switchgear installed in 5.4.3 provides supply for the pumps.

### **5.4.5 Second Half Switchgear Installation**

Cable entry holes may have to be drilled. The second half of the new switchgear may now be installed. It incorporates No.2 feeder, No.2 VSD supply, No.3 Transformer feeder as well as bus tie and bus transition cabinet.





## 6 PROTECTION RELAYS

Many protection relay options are available for selection. The choice of switchgear manufacturer will most likely determine the type of relay used. The modern relays are all similar in functionality with most able to communicate with SCADA systems via optics, Ethernet or RS485. All have capabilities to monitor KW, Amps, KVAR and power factor as a minimum.

Given the large size of the VSD's, it may be desirable to have the protection relays on the 11kV incomers able to analyse and display harmonic distortion.

The tripping and control voltage for the switchgear and associated protection relays will be 48VDC. A configuration change to the Battery Charger will be required as the existing power supply delivers 32VDC (a non-standard industry voltage).



## 7 INTAKE TOWER POWER SUPPLY

The intake tower distribution board is supplied from a 3.3kV/415V transformer mounted within the tower. The area may be subject to flooding in the future and so the possibility of a major incident is of concern. A request in the GAWB scope was to supply the intake tower DB directly with a supply from the 415V distribution board at the auxiliary intake tower.

A cable run from the auxiliary intake tower to the existing intake tower DB of around 160 metres will cost approximately \$14,000 to \$18,000, when consideration is given to the cost of crantage, cable, required elevated work platform and labour.

The available supply capacity at the auxiliary intake tower DB was insufficient to add the maximum demand of the existing intake tower DB. Interlocking of loads would have to be implemented to limit the demand on the supply.

An alternative solution is to install a water level transducer at a location that will supply continuous water level information to a networked PLC. On sensing an impending high water level, the PLC will send a signal to trip the circuit breaker supplying 3.3kV to the intake tower, thus disconnecting all power to both intake towers. The 3.3kV supply links to the existing intake tower may then be removed at the pad mount transformer located at the auxiliary intake tower. After by-passing the water high level alarm, the power can be restored to the auxiliary tower pad mounted transformer.

It is understood that the selection, recording and installation of a water level sensing device is being investigated under a separate project. Associated costs have not been included in this report.



## **8 LOAD CENTRE LC01**

The office distribution board is currently supplied by either of two house transformers located in the 11kV Switchroom. As part of the HV upgrade these house transformers will be removed. The office DB will then be supplied from load centre LC01 located in the compressor room.

A new supply cable will be run between the office DB and spare cell in LC01.

## **9 RIVER DISCHARGE POWER SUPPLY**

The river discharge area has no permanent power supply available requiring the use of a portable generator. Power is required to operate a hydraulic power pack which in turn is used to operate hydraulic discharge valves.

It is proposed to run a new cable from a distribution board in the pump station to a distribution board at the river discharge. Most of the cost of this exercise is to excavate a 100m long trench to accommodate the new cable. It is proposed to size the cable to allow for the installation of a 20A three phase outlet, as well as 240V light and power.

## **10 11KV SUPPLY ISOLATION**

Included in the HV upgrade will be the installation of air break switches with earthing capability at the two 11kV aerial termination poles at the GAWB side of the spillway. This modification will greatly streamline GAWB isolation procedures for HV switchgear access.



## 11 COSTING

The following estimate has been prepared using a combination of budget pricing from equipment and local installation contractors. This estimate has a tolerance of +/- 30%, and as presented does not include any contingency or escalation factors. Accordingly, a contingency allowance of +30% is recommended for budgeting purposes.

### 11.1 Cost Estimate Summary of Options

Table 1

	Detail	Cost Est. \$
<b>1</b>	<b>OPTION 1</b>	
1.1	11kV switchgear cost	\$300, 000.00
1.2	3.3kV switchgear cost	\$300, 000.00
1.3	Cost associated with use of portable substation	\$104, 000.00
1.4	Crane hire, misc material & labour	\$132, 000.00
	<b>Sub Total</b>	<b>\$836, 000.00</b>
<b>2</b>	<b>OPTION 2</b>	
2.1	11kV switchgear cost	\$300, 000.00
2.2	3.3kV switchgear cost	\$300, 000.00
2.3	Ring Main Unit cost	\$30, 000.00
2.4	Cost associated with use of portable substation	\$104, 000.00
2.5	Cable costs	\$30, 000.00
2.6	Crane hire, misc material & labour	\$158, 000.00
	<b>Sub Total</b>	<b>\$922, 000.00</b>
<b>3</b>	<b>OPTION 3</b>	
3.1	11kV switchgear cost	\$300, 000.00
3.2	3.3kV switchgear cost	\$300, 000.00
3.3	Ring Main Unit cost	\$25, 000.00
3.4	Fuse Links cost	\$3, 000.00
3.5	Transformer installation costs	\$15,000.00
3.6	Cable costs	\$45, 000.00
3.7	Crane hire, misc material & labour	\$167, 000.00
	<b>Sub Total</b>	<b>\$855, 000.00</b>



## 11.2 Cost Estimate Summary of Common Project Components

Table 2

	<b>Detail</b>	<b>Cost Est. \$</b>
<b>1</b>	<b>Hire of 415V generator</b>	\$10, 000.00
<b>1.1</b>	<b>Intake tower power supply</b>	
1.2	Cost of new distribution board	\$8, 000.00
1.3	Crane hire, misc material & labour	\$12, 500.00
<b>2</b>	<b>River Discharge power supply</b>	
2.1	Cost of new distribution board	\$1, 500.00
2.2	Cable costs	\$6, 500.00
2.3	Backhoe hire, misc material & labour	\$11, 300.00
<b>3</b>	Allowance for HV switchroom compliance cost	\$20, 000.00
<b>4</b>	Allowance for fire protection installation	\$30, 000.00
<b>5</b>	<b>Air Break Switches</b>	
5.1	Cost of switches	\$6, 400.00
5.2	Work platform hire, misc material & labour	\$21, 400.00
<b>6</b>	<b>Isolation Links</b>	
6.1	Cost of links	\$5, 600.00
6.2	Work platform hire, misc material & labour	\$3, 000.00
<b>7</b>	Office distribution board supply	\$1, 600.00
7.1	Welcon Design Consultancy Fees	\$200, 000.00
	<b>Sub Total</b>	<b>\$337, 800.00</b>
	Total Project Cost Choosing <b>Option 1</b>	<b>\$1,173, 800.00</b>
	Total Project Cost Choosing <b>Option 2</b>	<b>\$1,259, 800.00</b>
	Total Project Cost Choosing <b>Option 3</b>	<b>\$1,192, 800.00</b>



## 12 RECOMMENDATION

It is recommended that Option 3 be adopted for the HV upgrade project.

Option 3 provides a higher level of redundancy than is currently in place or would be provided by option 2. The utilization of GAWB spare 3MVA transformer not only offers improved redundancy at a reduced cost, but it provides the required redundancy during the construction phase. Also, by using the spare transformer in the proposed configuration it relieves the requirement for GAWB to maintain this transformer in the storage facility.

The option proposed is by no means an ideal design, but it is tabled with the knowledge that the available space in the 11kV switchroom is limited and the addition of more switchgear is not ideal. Also, it takes advantage of the available spare transformer which had become a maintenance issue for GAWB.

Finally, the proposal has been made with consideration given to limiting the budget necessary to carry out the upgrade.



## **APPENDIX A**

### Option 2 Drawings



The Option 2 drawings are listed in Table A.1

**Table A.1:** Option 2 Drawings

<b>Drawing</b>	<b>Revision</b>	<b>Title</b>	<b>Page</b>
GJ543-DW-01 Sheet 1	B	GLADSTONE AREA WATER BOARD AWOONGA DAM OVERALL SITE SUPPLY HIGH VOLTAGE MODIFICATIONS – OPTION 2 SINGLE LINE DIAGRAM	32
GJ543-DW-01 Sheet 2	B	GLADSTONE AREA WATER BOARD AWOONGA DAM OVERALL SITE SUPPLY HIGH VOLTAGE MODIFICATIONS – OPTION 2 SINGLE LINE DIAGRAM	33



1 2 3 4 5 6 7 8 9 10 11 12

A B C D E F G H

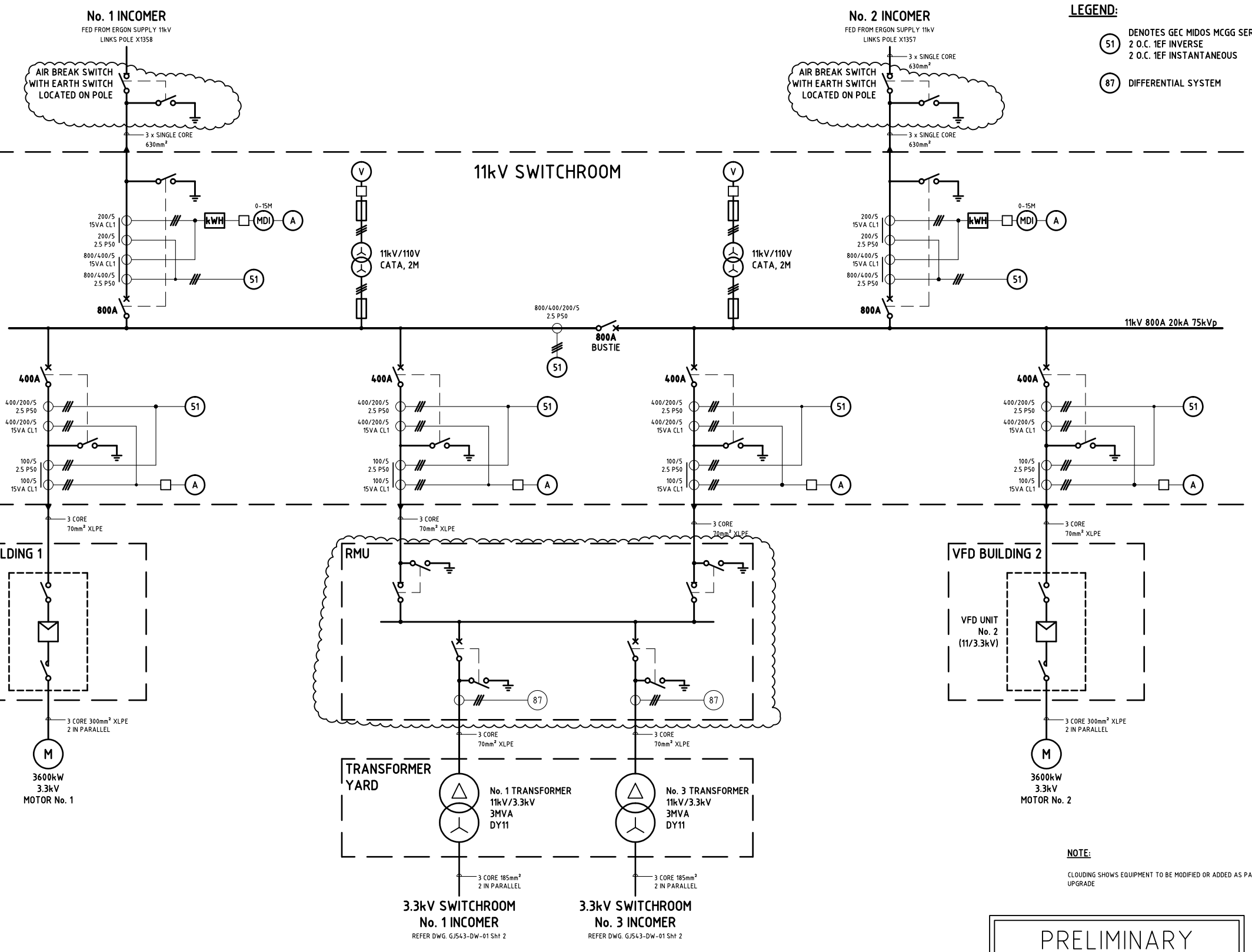

**LEGEND:**  
 (51) DENOTES GEC MIDOS MCGG SERIES OVERCURRENT RELAYS  
 2 O.C. 1EF INVERSE  
 2 O.C. 1EF INSTANTANEOUS  
 (87) DIFFERENTIAL SYSTEM

**NOTE:**  
 CLOUDING SHOWS EQUIPMENT TO BE MODIFIED OR ADDED AS PART OF PROPOSED UPGRADE

PRELIMINARY

				CONTRACTORS LOGO				WELCON TECHNOLOGIES PTY. LTD. Level 2, 500 Grandderson Street (PO Box 307) GLADSTONE QLD 4680 Phone: (07) 4274 0100 Fax: (07) 4272 4880		NAME DATE TITLE		GLADSTONE AREA WATER BOARD AWOONGA DAM OVERALL SITE SUPPLY HIGH VOLTAGE MODIFICATIONS - OPTION 2 SINGLE LINE DIAGRAM		
B MINOR DRAWING MODIFICATIONS A ISSUED FOR COMMENT/REVIEW				CONTRACTOR DWG. No.		THIS DRAWING REMAINS THE PROPERTY OF WELCON TECHNOLOGIES. IT MAY BE SUBJECT TO RECALL AT ANY TIME AND MUST NOT BE REPRODUCED IN PART OR WHOLE OR ITS CONTENTS DIVULGED TO THIRD PARTIES WITHOUT PRIOR WRITTEN APPROVAL FROM WELCON TECHNOLOGIES.		DRAFTER DRAFT CHK. ENG. CHK. APPROVED CLIENT APP.		CONTRACT No. DRAWING No. GJ543-DW-01 Sht 1 SCALE N.T.S. CAD FILE No GJ543DW01Sht1REVB		REV B		
REV	REVISION DESCRIPTION	DRN	CHK	DATE	DRAWING No.	REFERENCE DRAWING TITLE								
1		2		3		4								

BORDER SCALE  
 0 50mm 100mm

**LEGEND:**

- (51) DENOTES GEC MIDOS MCGG SERIES OVERCURRENT RELAYS  
2 O.C. 1EF INVERSE  
2 O.C. 1EF INSTANTANEOUS
- (87) DIFFERENTIAL SYSTEM

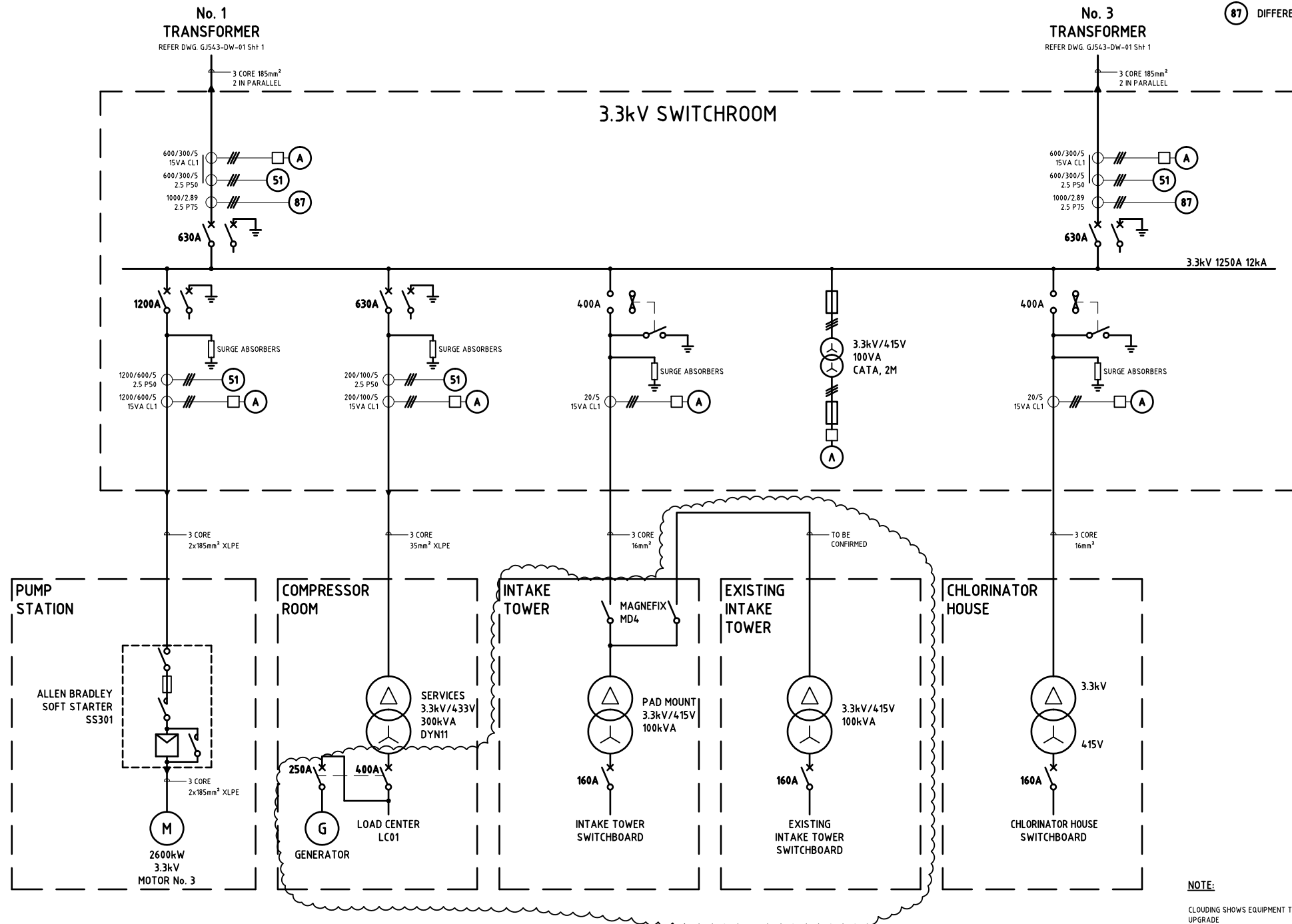

**NOTE:**

CLOUDING SHOWS EQUIPMENT TO BE MODIFIED OR ADDED AS PART OF PROPOSED UPGRADE

PRELIMINARY

CONTRACTORS LOGO						 <p><b>WELCON TECHNOLOGIES PTY. LTD.</b> Level 3, 100 Queensland Street PO Box 307 GLADSTONE QLD 4680 Phone: (07) 4274 0000 Fax: (07) 4274 4880</p>			<table border="1" style="width: 100%;"> <tr> <th>NAME</th> <th>DATE</th> <th>TITLE</th> </tr> <tr> <td>DRAFTER</td> <td></td> <td></td> </tr> <tr> <td>DRAFT CHK.</td> <td></td> <td></td> </tr> <tr> <td>ENG. CHK.</td> <td></td> <td></td> </tr> <tr> <td>APPROVED</td> <td></td> <td></td> </tr> <tr> <td>CLIENT APP.</td> <td></td> <td></td> </tr> </table>		NAME	DATE	TITLE	DRAFTER			DRAFT CHK.			ENG. CHK.			APPROVED			CLIENT APP.			<p><b>GLADSTONE AREA WATER BOARD</b> <b>AWOONGA DAM OVERALL SITE SUPPLY</b> <b>HIGH VOLTAGE MODIFICATIONS - OPTION 2</b> <b>SINGLE LINE DIAGRAM</b></p>		
NAME	DATE	TITLE																													
DRAFTER																															
DRAFT CHK.																															
ENG. CHK.																															
APPROVED																															
CLIENT APP.																															
CONTRACTOR DWG. No.						CONTRACT No.		DRAWING No.		REV																					
THIS DRAWING REMAINS THE PROPERTY OF WELCON TECHNOLOGIES. IT MAY BE SUBJECT TO RECALL AT ANY TIME AND MUST NOT BE REPRODUCED IN PART OR WHOLE OR ITS CONTENTS DIVULGED TO THIRD PARTIES WITHOUT PRIOR WRITTEN APPROVAL FROM WELCON TECHNOLOGIES.						GJ543-DW-01 Sht 2		GJ543DW02SHT1REV B		B																					
REVISION DESCRIPTION						SCALE		N.T.S.		CAD FILE No																					
REV	1	2	3	4	5	6	7	8	9	10	11	12																			

BORDER SCALE  
0 50mm 100mm



## **APPENDIX B**

### Option 3 Drawings



The Option 3 drawings are listed in Table B.1.

**Table B.1:** Option 3 Drawings

<b>Drawing</b>	<b>Revision</b>	<b>Title</b>	<b>Page</b>
GJ543-DW—02 Sheet 1	B	GLADSTONE AREA WATER BOARD AWOONGA DAM OVERALL SITE SUPPLY HIGH VOLTAGE MODIFICATIONS – OPTION 3 SINGLE LINE DIAGRAM	36
GJ543-DW—02 Sheet 2	B	GLADSTONE AREA WATER BOARD AWOONGA DAM OVERALL SITE SUPPLY HIGH VOLTAGE MODIFICATIONS – OPTION 3 SINGLE LINE DIAGRAM	37

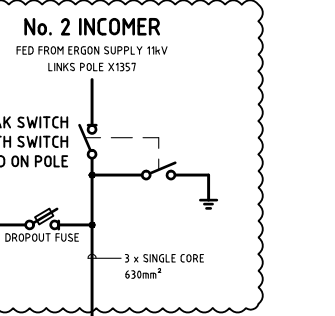
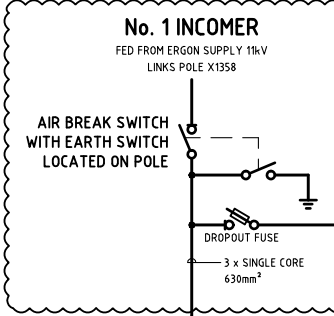

**LEGEND:**

- (51) DENOTES GEC MIDOS MCGG SERIES OVERCURRENT RELAYS  
2 O.C. 1EF INVERSE  
2 O.C. 1EF INSTANTANEOUS
- (87) DIFFERENTIAL SYSTEM

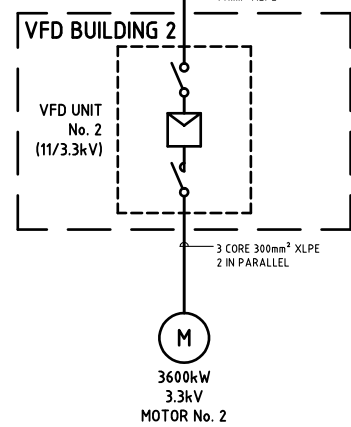
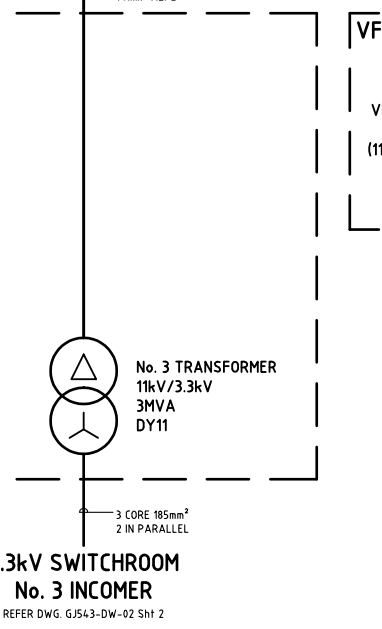
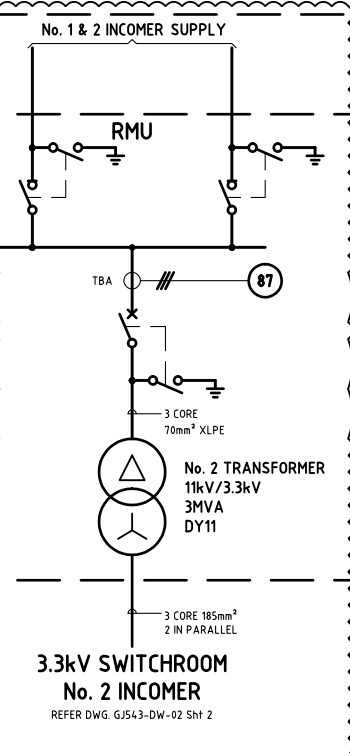
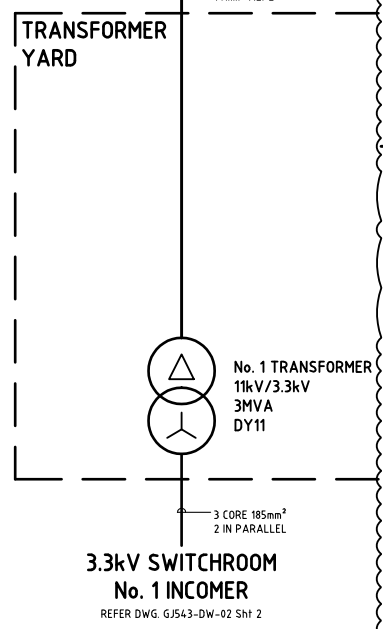
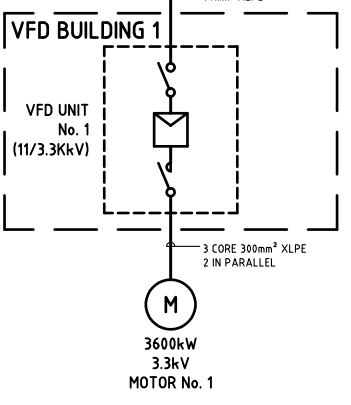
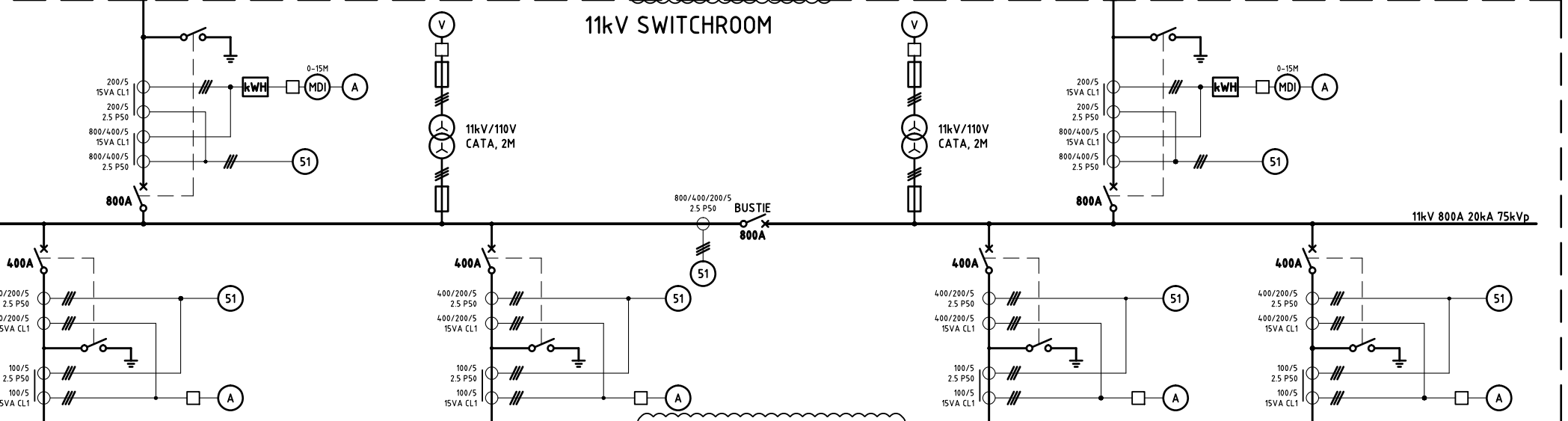

**NOTE:**  
CLOUDING SHOWS EQUIPMENT TO BE MODIFIED OR ADDED AS PART OF PROPOSED UPGRADE

PRELIMINARY

REVISIONS				CONTRACTORS LOGO			WELCON TECHNOLOGIES PTY. LTD. Level 3, 780 Queensland Street PO Box 307 GLADSTONE QLD 4680 Phone: (07) 4972 0020 Fax: (07) 4972 4880			NAME		DATE		TITLE	
B	MINOR DRAWING MODIFICATIONS						WELCON TECHNOLOGIES			DRAFTER				GLADSTONE AREA WATER BOARD AWOONGA DAM OVERALL SITE SUPPLY HIGH VOLTAGE MODIFICATIONS - OPTION 3 SINGLE LINE DIAGRAM	
A	ISSUED FOR COMMENT/REVIEW									DRAFT CHK.				CONTRACT No.	
REV	REVISION DESCRIPTION	DRN	CHK	DATE	DRAWING No.	REFERENCE DRAWING TITLE	CONTRACTOR DWG. No.			APPROVED				DRAWING No. GJ543-DW-02 Sht 1	
1										CLIENT APP.				SCALE N.T.S. CAD FILE No. GJ543D02Sht1REVB	

1 2 3 4 5 6 7 8 9 10 11 12

A B C D E F G H

**LEGEND:**  
 (51) DENOTES GEC MIDOS MCGG SERIES OVERCURRENT RELAYS  
 2 O.C. 1EF INVERSE  
 2 O.C. 1EF INSTANTANEOUS  
 (87) DIFFERENTIAL SYSTEM

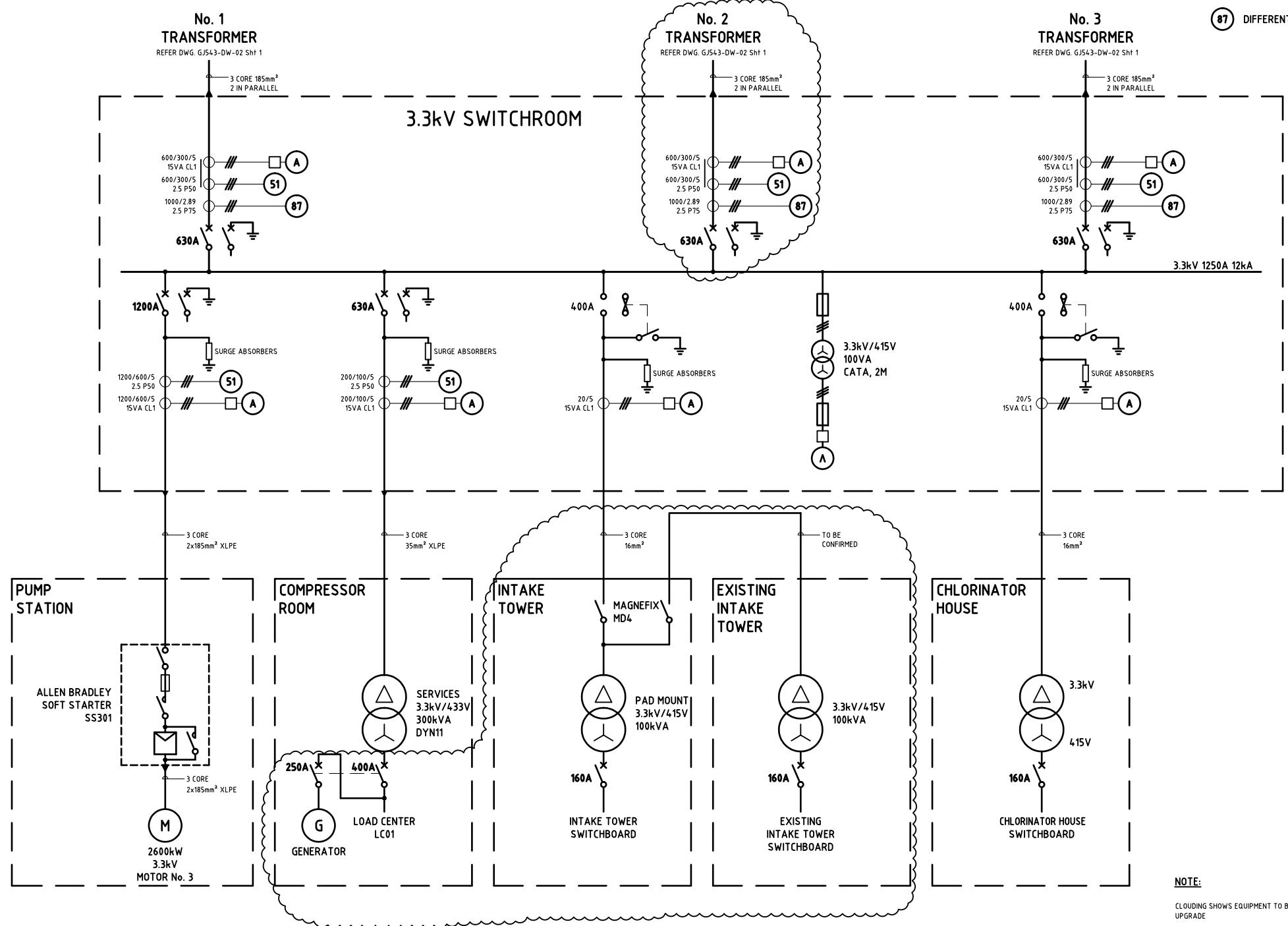

**NOTE:**  
 CLOUDING SHOWS EQUIPMENT TO BE MODIFIED OR ADDED AS PART OF PROPOSED UPGRADE

PRELIMINARY

				CONTRACTORS LOGO				NAME DATE TITLE		GLADSTONE AREA WATER BOARD AWOONGA DAM OVERALL SITE SUPPLY HIGH VOLTAGE MODIFICATIONS - OPTION 3 SINGLE LINE DIAGRAM	
				CONTRACTOR DWG. No.		WELCON TECHNOLOGIES PTY. LTD. Level 2, 700 Queensland Street (PO Box 387) GLADSTONE QLD 4680 Phone: (07) 4972 4880 Fax: (07) 4972 4880		DRAFTER DRAFT CHK. ENG. CHK. APPROVED CLIENT APP.		CONTRACT No. DRAWING No. GJ543-DW-02 Sht 2 SCALE N.T.S. CAD FILE No GJ543DW02Sht1REV B	
REV	REVISION DESCRIPTION	DRN	CHK	DATE	DRAWING No.	REFERENCE DRAWING TITLE	THIS DRAWING REMAINS THE PROPERTY OF WELCON TECHNOLOGIES. IT MAY BE SUBJECT TO RECALL AT ANY TIME AND MUST NOT BE REPRODUCED IN PART OR WHOLE OR ITS CONTENTS DIVULGED TO THIRD PARTIES WITHOUT PRIOR WRITTEN APPROVAL FROM WELCON TECHNOLOGIES.				REV B

1 2 3 4 5 6 7 8 9 10 11 12

**Level 3, 100 Goondoon Street  
GLADSTONE QLD 4680, Australia  
Phone:+617 4976 0600  
Fax:+617 4972 4820**

**Unit 1, 33 Plume Street  
TOWNSVILLE QLD 4810, Australia  
Phone:+617 4721 1448  
Fax:+617 4721 1148**

**Web Site:  
<http://www.welcon.com.au>**

**Email:  
[welcon.gladstone@welcon.com.au](mailto:welcon.gladstone@welcon.com.au)  
[welcon.townsville@welcon.com.au](mailto:welcon.townsville@welcon.com.au)**

The logo for Welcon, featuring the word "Welcon" in a stylized, italicized blue font with a white outline, set within a white oval shape with a blue border.

**Welcon**